



Installation Instructions for the

# Cash Drop Box

*SK-700 Series*

Fig. 1

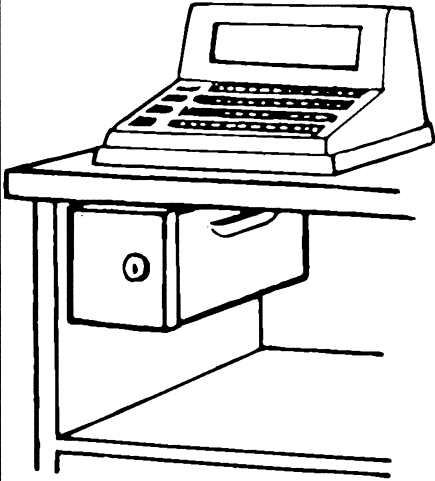

Fig. 2

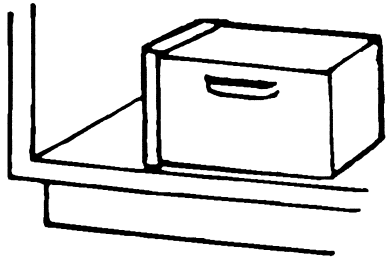

Fig. 3

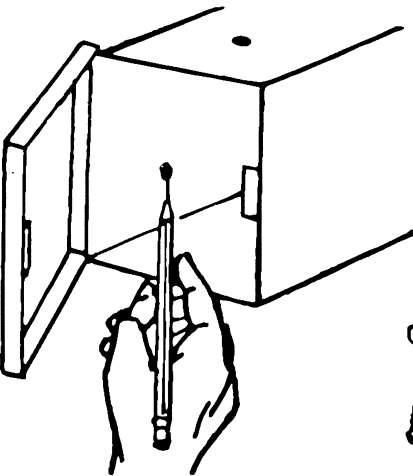
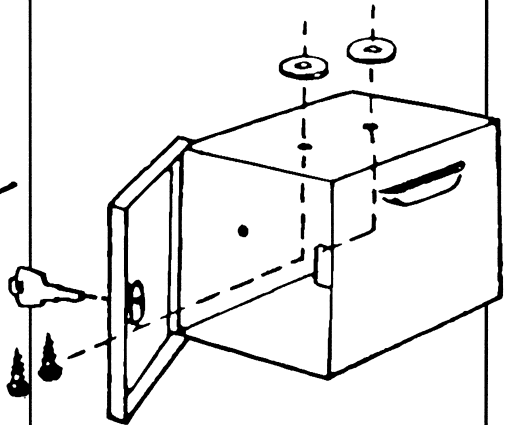

Fig. 4



## Step 1.

Check Hardware:  
(which includes)

- 2 sets of (2) Identical Keys
- (2) Heavy-Duty Wood Screws
- (4) Steel Spacers

## Step 2.

Your cash drop box may be mounted in (3) three different positions. Screw holes on top panel, left panel and bottom panel allow for these options:

- (A) Under counter mount with door facing out.  
(See Fig. 1).
- (B) Under counter mount with door facing left. (Be sure to leave clearance for door access. (See Fig. 2).
- (C) Floor mount or counter bottom shelf mount.  
(Facing out or left).

## Step 3.

- (1) Place cash drop box in desired position. Mark screw holes with pencil. (See Fig. 3).
- (2) Pre-drill screw holes on pencil marks for easy screw installation.
- (3) Position spacers between cash box outer walls and counter or floor structures. Install screws with screw driver from inside cash box. (See Figs. 4 & 5).
- (4) Turn key counter-clockwise to lock and remove key. Your cash drop box is now ready to use.

Fig. 5

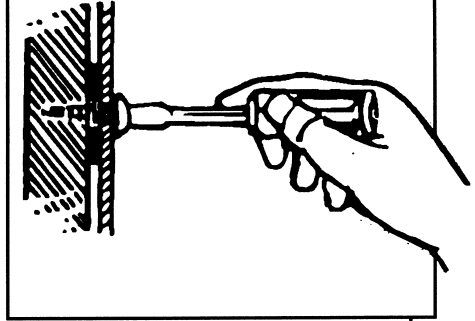

SCI-9551



**SE-KURE CONTROLS,® INC.**

3714 Runge St. • Franklin Pk., IL 60131 • (708) 288-1111

**1-800-322-2435**